Cleanrooms and associated controlled environments —

Part 9:
**Classification of surface cleanliness by
particle concentration**

Salles propres et environnements maîtrisés apparentés —

*Partie 9: Classification de la propreté des surfaces par la concentration
de particules*





COPYRIGHT PROTECTED DOCUMENT

© ISO 2012

All rights reserved. Unless otherwise specified, no part of this publication may be reproduced or utilized in any form or by any means, electronic or mechanical, including photocopying and microfilm, without permission in writing from either ISO at the address below or ISO's member body in the country of the requester.

ISO copyright office
Case postale 56 • CH-1211 Geneva 20
Tel. + 41 22 749 01 11
Fax + 41 22 749 09 47
E-mail copyright@iso.org
Web www.iso.org

Published in Switzerland

Contents

Page

Foreword	iv
Introduction	v
1 Scope	1
2 Normative references	1
3 Terms and definitions	1
4 Abbreviated terms	2
5 Classification system	3
5.1 ISO-SCP classification format	3
5.2 Designation	6
5.3 General information on surface cleanliness by particle concentration	6
6 Demonstration of compliance	6
6.1 Principle	6
6.2 Testing	6
6.3 Test report	7
Annex A (informative) Surface characteristics	9
Annex B (informative) Descriptor for specific particle size ranges	12
Annex C (informative) Parameters influencing the SCP classification	15
Annex D (informative) Measurement methods for determining surface cleanliness by particle concentration	17
Bibliography	25

Foreword

ISO (the International Organization for Standardization) is a worldwide federation of national standards bodies (ISO member bodies). The work of preparing International Standards is normally carried out through ISO technical committees. Each member body interested in a subject for which a technical committee has been established has the right to be represented on that committee. International organizations, governmental and non-governmental, in liaison with ISO, also take part in the work. ISO collaborates closely with the International Electrotechnical Commission (IEC) on all matters of electrotechnical standardization.

International Standards are drafted in accordance with the rules given in the ISO/IEC Directives, Part 2.

The main task of technical committees is to prepare International Standards. Draft International Standards adopted by the technical committees are circulated to the member bodies for voting. Publication as an International Standard requires approval by at least 75 % of the member bodies casting a vote.

Attention is drawn to the possibility that some of the elements of this document may be the subject of patent rights. ISO shall not be held responsible for identifying any or all such patent rights.

ISO 14644-9 was prepared by Technical Committee ISO/TC 209, *Cleanrooms and associated controlled environments*.

ISO 14644 consists of the following parts, under the general title *Cleanrooms and associated controlled environments*:

- *Part 1: Classification of air cleanliness*
- *Part 2: Specifications for monitoring to prove continued compliance with ISO 14644-1*
- *Part 3: Test methods*
- *Part 4: Design, construction and start-up*
- *Part 5: Operations*
- *Part 6: Vocabulary*
- *Part 7: Separative devices (clean air hoods, gloveboxes, isolators, and mini-environments)*
- *Part 8: Classification of air cleanliness by chemical concentration*
- *Part 9: Classification of surface cleanliness by particle concentration*
- *Part 10: Classification of surface cleanliness by chemical concentration*

Attention is also drawn to ISO 14698, *Cleanrooms and associated controlled environments — Biocontamination control*:

- *Part 1: General principles and methods*
- *Part 2: Evaluation and interpretation of biocontamination data*

Introduction

Cleanrooms and associated controlled environments provide for the control of contamination to levels appropriate for accomplishing contamination-sensitive activities. Products and processes that benefit from the control of contamination include those in such industries as aerospace, microelectronics, optics, nuclear, and life sciences (pharmaceuticals, medical devices, food, healthcare).

ISO 14644-1 to ISO 14644-8 and ISO 14698-1 and ISO 14698-2 (biological contamination) deal exclusively with airborne particle and chemical contamination. Many factors, besides the classification of surface cleanliness, should be considered in the design, specification, operation and control of cleanrooms and other controlled environments. These factors are covered in some detail in other parts of ISO 14644 and ISO 14698.

This part of ISO 14644 provides a classification for the determination and designation of surface cleanliness levels based on particle concentrations. This part of ISO 14644 also lists some methods of testing, as well as procedure(s) for determining the concentration of particles on surfaces.

Where regulatory agencies impose supplementary guidelines or restrictions, appropriate adaptations of the testing procedures might be required.

Cleanrooms and associated controlled environments —

Part 9: Classification of surface cleanliness by particle concentration

1 Scope

This part of ISO 14644 establishes the classification of cleanliness levels on solid surfaces by particle concentration in cleanrooms and associated controlled environment applications. Recommendations on testing and measuring methods, as well as information about surface characteristics, are given in Annexes A to D.

This part of ISO 14644 applies to all solid surfaces in cleanrooms and associated controlled environments, such as walls, ceilings, floors, working environments, tools, equipment and products. The classification of surface cleanliness by particle concentration (SCP) is limited to particles between 0,05 μm and 500 μm .

The following issues are not considered in this part of ISO 14644:

- requirements for the cleanliness and suitability of surfaces for specific processes;
- procedures for the cleaning of surfaces;
- material characteristics;
- references to interactive bonding forces or generation processes that are usually time-dependent and process-dependent;
- selection and use of statistical methods for classification and testing;
- other characteristics of particles, such as electrostatic charge, ionic charges, microbiological state, etc.

2 Normative references

The following referenced documents are indispensable for the application of this document. For dated references, only the edition cited applies. For undated references, the latest edition of the referenced document (including any amendments) applies.

ISO 14644-6:2007, *Cleanrooms and associated controlled environments — Part 6: Vocabulary*

3 Terms and definitions

For the purposes of this document, the terms and definitions given in ISO 14644-6:2007 and the following apply.

3.1

descriptor for specific particle size ranges

differential descriptor that expresses SCP level within specific particle size ranges

NOTE The descriptor may be applied to particle size ranges of special interest or those particle size ranges that are outside the range of the classification system, and specified independently or as a supplement to the SCP classes.

- 3.2**
direct measurement method
assessment of the contamination without any intermediate steps
- 3.3**
indirect measurement method
assessment of the contamination with intermediate steps
- 3.4**
solid surface
boundary between the solid and a second phase
- 3.5**
surface particle
solid and/or liquid matter adhered and discretely distributed on a surface of interest, excluding film-like matter that covers the whole surface

NOTE Surface particles are adhered via chemical and/or physical interactions.

- 3.6**
surface cleanliness by particle concentration
SCP
condition of a surface with respect to its particle concentration

NOTE The surface cleanliness depends upon material and design characteristics, stress loads (complexity of loads acting on a surface) and prevailing environmental conditions, along with other factors.

- 3.7**
surface cleanliness by particle concentration class
SCP class
grading number stating the maximum allowable surface concentration, in particles per square metre, for a considered size of particles (SCP Classes 1 to 8)

- 3.8**
surface cleanliness by particle concentration classification
SCP classification
level (or the process of specifying or determining the level) that represents maximum allowable surface concentrations, in particles per square metre, for considered sizes of particles, expressed in terms of an ISO SCP Class *N*

- 3.9**
surface particle concentration
number of individual particles per unit of surface area under consideration

4 Abbreviated terms

For the purposes of this document, the following abbreviated terms apply.

- AFM atomic force microscopy
- CNC condensation nucleus counter
- EDX energy dispersive X-ray spectroscopy
- ESCA electron spectroscopy for chemical analysis
- ESD electrostatic discharge

IR	infrared (absorption spectroscopy)
OPC	optical particle counter
PET	polyethylene terephthalate
SCP	surface cleanliness by particle concentration
SEM	scanning electron microscopy
UV	ultraviolet (spectroscopy)
WDX	wavelength-dispersive X-ray spectroscopy

5 Classification system

5.1 ISO-SCP classification format

The class of surface cleanliness by particle concentration (SCP) in a cleanroom or associated controlled environment shall be designated by a classification number, N , specifying the maximum total particle concentration on surfaces permitted for a considered particle size. N shall be determined from the following equation with the maximum permitted total particle concentration on the surface, $C_{SCP;D}$, in particles per square metre of surface, for each considered particle size, D :

$$C_{SCP;D} = k \frac{10^N}{D} \quad (1)$$

where

$C_{SCP;D}$ is the maximum permitted total surface concentration, in particles per square metre of surface, of particles that are equal to or larger than the considered particle size; $C_{SCP;D}$ is rounded to the nearest whole number, using no more than three significant figures;

N is the SCP classification number, which is limited to SCP Class 1 through SCP Class 8; SCP Class number N is represented by the measured particle diameter D , in micrometres;

NOTE N refers to the exponent base 10 for the concentration of particles at the reference particle size of 1 μm .

D is the considered particle size, in micrometres.

k is a constant 1, in micrometres.

NOTE 1 The SCP class based on the particle concentration can be a time- and process-dependent value due to the dynamic characteristics of particle generation and transportation.

NOTE 2 Due to the complexity of statistical evaluations and readily available additional references, the selection and use of statistical methods for classification and testing are not described in this part of ISO 14644.

The concentration $C_{SCP;D}$, as derived from Equation (1), shall serve as the definitive value. Table 1 presents selected SCP classes and corresponding maximum cumulative permitted total surface concentrations for considered particle sizes.

Figure 1 provides a representation of the selected classes in graphical form.

Table 1 — Selected SCP classes for cleanrooms and associated controlled environments

Units in particles per square metre

SCP Class	Particle size								
	≥ 0,05 µm	≥ 0,1 µm	≥ 0,5 µm	≥ 1 µm	≥ 5 µm	≥ 10 µm	≥ 50 µm	≥ 100 µm	≥ 500 µm
SCP Class 1	(200)	100	20	(10)					
SCP Class 2	(2 000)	1 000	200	100	(20)	(10)			
SCP Class 3	(20 000)	10 000	2 000	1 000	(200)	(100)			
SCP Class 4	(200 000)	100 000	20 000	10 000	2 000	1 000	(200)	(100)	
SCP Class 5		1 000 000	200 000	100 000	20 000	10 000	2 000	1 000	(200)
SCP Class 6		(10 000 000)	2 000 000	1 000 000	200 000	100 000	20 000	10 000	2 000
SCP Class 7				10 000 000	2 000 000	1 000 000	200 000	100 000	20 000
SCP Class 8						10 000 000	2 000 000	1 000 000	200 000

The values in Table 1 are concentrations of particles of the related particle size and SCP class per surface area of one square metre (1 m²) equal to or larger than the considered particle size ($C_{SCP;D}$).

For figures in parentheses, the corresponding particle sizes should not be used for classification purposes; select another particle size for classification.

The minimum area for testing should be statistically representative of the surface under consideration.

NOTE Classification of the lower SCP classes requires numerous measurements to establish a significant value.

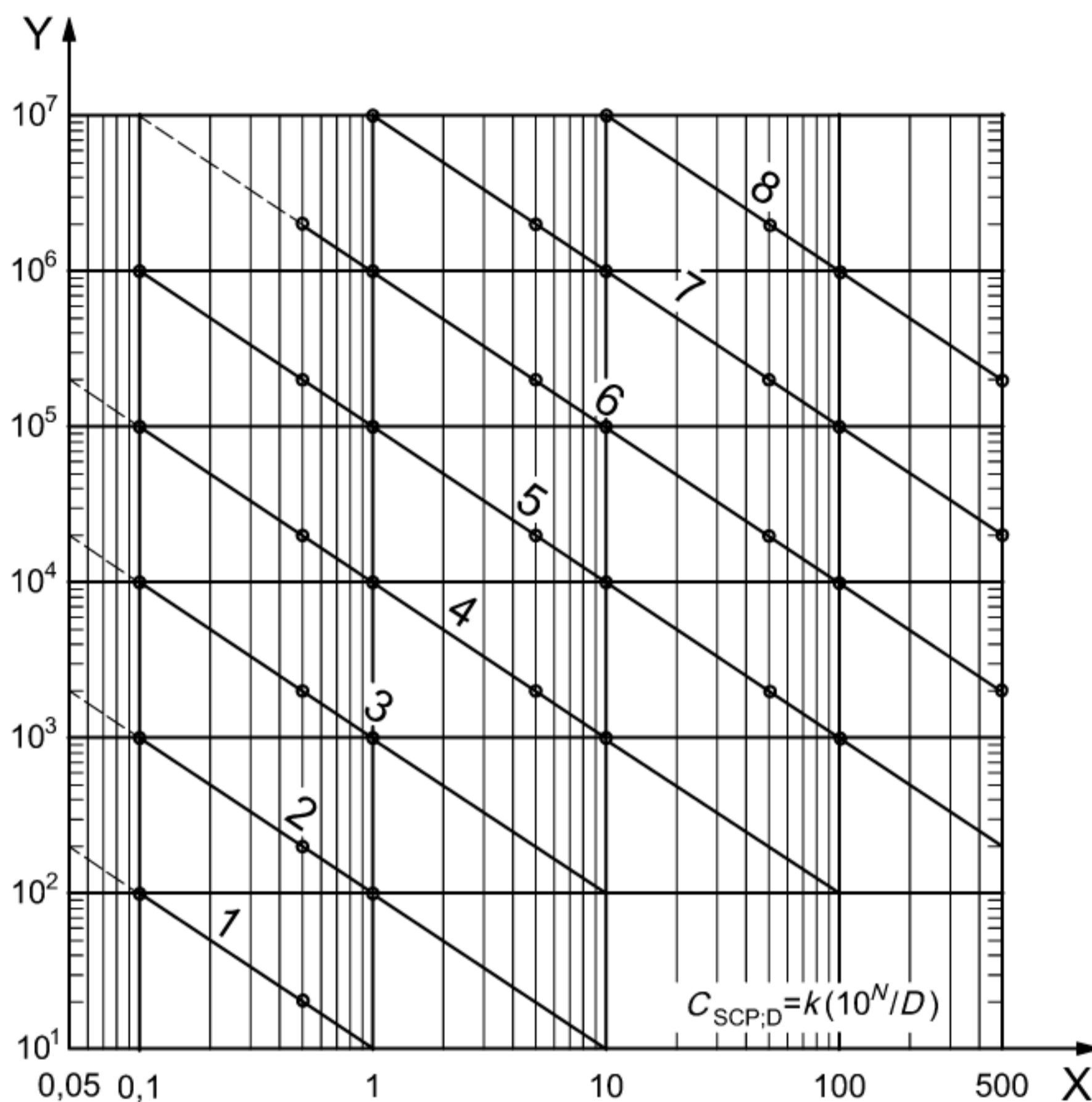

Key

X considered particle size, D (μm)
 Y particle concentration on a surface $\geq D$, $C_{\text{SCP};D}$ (particles/ m^2)

- 1 SCP Class 1
- 2 SCP Class 2
- 3 SCP Class 3
- 4 SCP Class 4
- 5 SCP Class 5
- 6 SCP Class 6
- 7 SCP Class 7
- 8 SCP Class 8

The solid classification lines shown on the graph shall be used for classification purposes. The dashed lines should not be used for classification purposes.

NOTE Particle distribution on surfaces typically is not a normal distribution, but is affected by different factors, such as roughness, porosity, electrostatic charge, deposition mechanisms, etc. (see Annex A).

EXAMPLE SCP Class 5 ($1 \mu\text{m}$) signifies that 1 m^2 of surface may carry a maximum of 10^5 particles with a considered particle size $\geq 1 \mu\text{m}$ ($D = 1$). SCP Class 5 ($10 \mu\text{m}$) signifies that 1 m^2 of surface may carry a maximum of 10^4 particles per square metre with a considered particle size $\geq 10 \mu\text{m}$ ($D = 10$). Any other measured particle size ($D = x$) which leads to a concentration that lies below the relevant SCP class line is within the specification of SCP Class 5 ($x \mu\text{m}$).

Figure 1 — SCP classes

For particle sizes out of the classification system and in cases where only a narrow particle range or individual particle sizes are of interest, a descriptor can be used (see Annex B).

5.2 Designation

The SCP class number shall be formatted as follows: SCP Class N (D μm).

The designation of the SCP class for cleanrooms and associated controlled environments shall also include the following:

- a) the surface type measured;
- b) the surface area measured;
- c) the measurement method applied.

Details of measurement methods applied, including sampling techniques and measurement devices, should be retrieved from test reports.

The considered particle size should be determined by agreement between the customer and supplier.

The SCP classification shall be stated in relation to the measured particle size diameter.

EXAMPLE 1 SCP Class 2 (0,1 μm); wafer or glass substrate, surface area: 310 cm^2 ; surface particle counter.

EXAMPLE 2 SCP Class 5 (0,5 μm); inner wall of a bottle, surface area: 200 cm^2 ; liquid dispersion — liquid particle counter.

5.3 General information on surface cleanliness by particle concentration

Airborne particle concentration and surface particle concentration are generally related. The relationship is dependent on many factors, such as airflow turbulence, rate of deposition, time of deposition, deposition velocity, concentration within the air, and surface characteristics such as electrostatic charge (see A.2.4).

To determine surface cleanliness by particle concentration, various parameters (see Annex C) and surface characteristics (see Annex A) that influence testing should be taken into account.

6 Demonstration of compliance

6.1 Principle

Compliance with SCP class requirements, as specified by the customer, is verified by performing tests and by providing documentation of the results and conditions of the testing.

Details for demonstrating compliance (see 6.3) shall be agreed upon between the customer and supplier in advance of testing.

6.2 Testing

Tests performed to demonstrate compliance shall be conducted in a controlled environment using suitable test methods and calibrated instruments, whenever possible.

Direct and indirect test methods can be used for demonstrating compliance and are given in Annex D. The list of typical methods described is not exhaustive. Alternative methods of comparable accuracy may be specified by agreement.

NOTE Measurement by different methods, even when correctly applied, can produce different results of equal validity.

Repeated measurements are recommended.

The test method and environment shall be agreed upon between the customer and supplier.

Precautions should be taken to reduce electrostatic charge around the test zone, since electrostatic charge enhances particle deposition onto surfaces. If the surface is neither conductive, nor grounded or charge-neutralized, electrostatic charges might occur (see Annex A). Therefore, test results may vary.

6.3 Test report

The results from testing each surface shall be recorded and submitted as a comprehensive report, along with a statement of compliance or non-compliance with the specified SCP class(es).

The test report shall include as a minimum the following:

- a) basic data:
 - date and time of testing;
 - name/address of the testing organization;
 - name of testing personnel;
- b) references consulted:
 - standards;
 - guidelines;
 - regulations;
 - number and year of publication of this part of ISO 14644, i.e. ISO 14644-9:2012;
- c) environmental data:
 - environmental conditions for sampling (i.e. temperature, humidity, cleanliness);
 - environmental conditions for measurement (i.e. temperature, humidity, cleanliness) (not essential for use with direct methods);
 - location (room, etc.) used for the measurements;
- d) specimen:
 - clear identification of the test object;
 - description of the test object;
 - graph and/or sketch of test specimen;
- e) test setup:
 - photo and/or sketch of the test setup;
 - description of operating parameters;
 - description of measurement points;
 - description of hardware used in the test setup;

- f) measurement devices:
 - identification of the instrument(s) and measuring devices used and current calibration certificate(s);
 - measurement range of measuring devices used;
 - reference of calibration certificates;
- g) performing the test:
 - relevant details of the test procedure used, with any available data describing deviations from the test procedure (if agreed);
 - surface condition before sampling (e.g. after cleaning, after packaging, under atmospheric or vacuum conditions);
 - specified test and measurement procedure/method;
 - occupancy state(s) during sampling and measurement;
 - specified test method(s);
 - all agreed documentation (e.g. raw data, background particle concentrations, pictures, graphs, cleaning and packaging);
 - duration, location and position of sampling (not essential for use with direct methods);
 - duration, location and position of measurement (not essential for use with direct methods);
 - noticeable observations made during sampling/measurement, where applicable;
 - number of measurements performed;
 - clear identification of the position and the area of the surface measured and specific designations for coordinates of the surface, if applicable;
- h) results and analysis:
 - visual inspection of the test surface before and after measurement, where applicable;
 - measurement values and/or their analysis;
 - statement of data quality;
 - particle size ranges considered;
 - test results, including particle concentration data for given particle sizes, for all tests performed;
 - surface cleanliness by particle concentration class with designation expressed as SCP Class *N*;
 - acceptance criteria for the clean surface, if agreed between the customer and supplier.

Annex A (informative)

Surface characteristics

A.1 Surface description

A surface is commonly characterized by its texture (such as roughness, porosity), its mechanical properties (such as hardness) and its physicochemical properties (such as electrostatic surface charge and surface tension). Each of these properties should be considered before selecting a test method for the surface cleanliness classification, or as an aid for the interpretation of the test results.

A.2 Surface characteristics

A.2.1 Roughness

A.2.1.1 Description

As the roughness of a surface affects many of its physical properties, surface roughness is not easily described by one single parameter, nor is it an intrinsic property of the surface. Roughness exists in two principal planes: at right angles to the surface, where it may be characterized by height, and in the plane of the surface, identified as “texture” and characterized by waviness. The roughness of a surface can be determined by mechanical or optical methods.

A.2.1.2 Testing

A frequently used mechanical method for the determination of roughness is the stylus instrument (for example, see ISO 4287 or ISO 4288).

Frequently used optical methods for the determination of roughness and porous texture are microscopes (optical, confocal, interferometry, with/without tunnel effect, taper sectioning).

A.2.2 Porosity

A.2.2.1 Definition and description

Porosity is a measure of the void spaces in a material, and is expressed as a decimal between 0 and 1, or as a percentage between 0 % and 100 %.

- **Effective porosity** (also called open porosity) refers to the fraction of the total volume in which fluid flow is effectively taking place (this excludes dead-end pores or non-connected cavities).
- **Macroporosity** refers to pores equal to or greater than 50 nm in diameter. Fluid flow through macropores is described by bulk diffusion.
- **Mesoporosity** refers to pores equal to or greater than 2 nm but less than 50 nm in diameter.
- **Microporosity** refers to pores smaller than 2 nm in diameter. Movement in micropores is by activated diffusion.

A.2.2.2 Testing

There are several ways to estimate the porosity of a given material or mixture of materials, which is called material matrix.

The **volume/density method** is fast and highly accurate (normally within $\pm 2\%$ of the actual porosity). The volume and the weight of the material are measured. The weight of the material divided by the density of the material gives the volume that the material takes up, minus the pore volume. Therefore, the pore volume is simply equal to the total volume minus the material volume, or more directly (pore volume) = (total volume) – (material volume).

The **water saturation method** is slightly more difficult, but is more accurate and more direct. Take a known volume of the material and a known volume of water. Slowly dump the material into the water and allow it to saturate while pouring. Allow it to sit for a few hours to ensure that the material is fully saturated. Then remove the unsaturated water from the top of the beaker and measure its volume. The total volume of the water originally in the beaker minus the volume of water not saturated is the volume of the pore space, or again more directly (pore volume) = (total volume of water) – (unsaturated water).

Mercury intrusion porosimetry requires the sample to be placed in a special filling device that allows the sample to be evacuated, followed by the introduction of liquid mercury. The size of the mercury envelope is then measured as a function of increased applied pressure. The greater the applied pressure, the smaller the pore entered by mercury. Typically, this method is used over the range of pores from 300 μm to 0,0 035 μm . Because of increased safety concerns over the use of mercury, several non-mercury intrusion techniques have been developed and should be considered as alternatives.

Nitrogen gas adsorption is used to determine fine porosity in materials. In very small pores, nitrogen gas condenses on pore walls that are less than 0,090 μm in diameter. This condensation is measured either by volume or weight.

A.2.3 Hardness

There are many National and International Standards on hardness tests for each material type. Hardness is frequently measured by the penetrating force of a diamond ball or tip, by the indentation of a hard body or by the rebound properties of an impactor.

The Rockwell, Brinell, Shore and Vickers method for metals is covered by ASTM E18-07. Geometry and pressure are chosen at the beginning of the test, as a function of the thickness of the sample, the composition of the metal and the supposed hardness.

A.2.4 Static electricity

A.2.4.1 Definition and description

Static electricity is defined as an electrical charge caused by an imbalance of electrons on the surface of a material. This imbalance of electrons produces an electrostatic field that can influence the determination of the surface cleanliness of objects. Electrostatic discharge (ESD) is defined as the transfer of charge between bodies at different electrical potentials.

Any relative motion and physical separation of materials or flow of solids, liquids, or particle-laden gases can generate electrostatic charges. Common sources of ESD include personnel, items made from common polymeric materials, and processing equipment. ESD can damage parts by direct contact with a charged source or by electric fields emanating from charged objects.

Charged surfaces can attract and hold particle contaminants. If the selected measurement method to determine the surface cleanliness is based on an indirect detection of particles on surfaces (see D.2.3.3.5), these measurement results might be inaccurate, as the particle removal is diminished. Therefore, especially when using indirect measurement methods, action should be taken to reduce ESD effects.

A.2.4.2 Testing

Determination of the ESD properties of the specimen surfaces may be helpful in estimating the influence of the removal efficiency of particles from surfaces (e.g. IEC 61340-5-1, ISO 10015, IEST RP-CC022.2, SEMI E43-0301, SEMI E78-0706).

A.2.5 Superficial tension

A.2.5.1 Definition

Superficial tension is the energy necessary to increase the surface by one area unit. It is usually defined as γ and expressed in joules per square metre (J/m^2) or in newtons per metre (N/m).

A.2.5.2 Testing

The best-known method is the measurement of the contact angle by the “set drop” (see Reference [22] in the Bibliography).

When a drop of liquid is brought into contact with a flat solid surface, its shape depends on the molecular force within the liquid for cohesive force, or between the liquid and solid for adhesive force. The contact angle between the liquid and solid is used as the surface tension index (see Figure A.1). It is generally found that liquids with low surface tension easily wet most solid surfaces, giving a zero contact angle. The molecular adhesion between solid and liquid is greater than the cohesion between the molecules of the liquid.

The contact angle measurement is performed with an optical method ($\times 10$ to $\times 50$) magnifying the drop profile set on the flat solid surface.

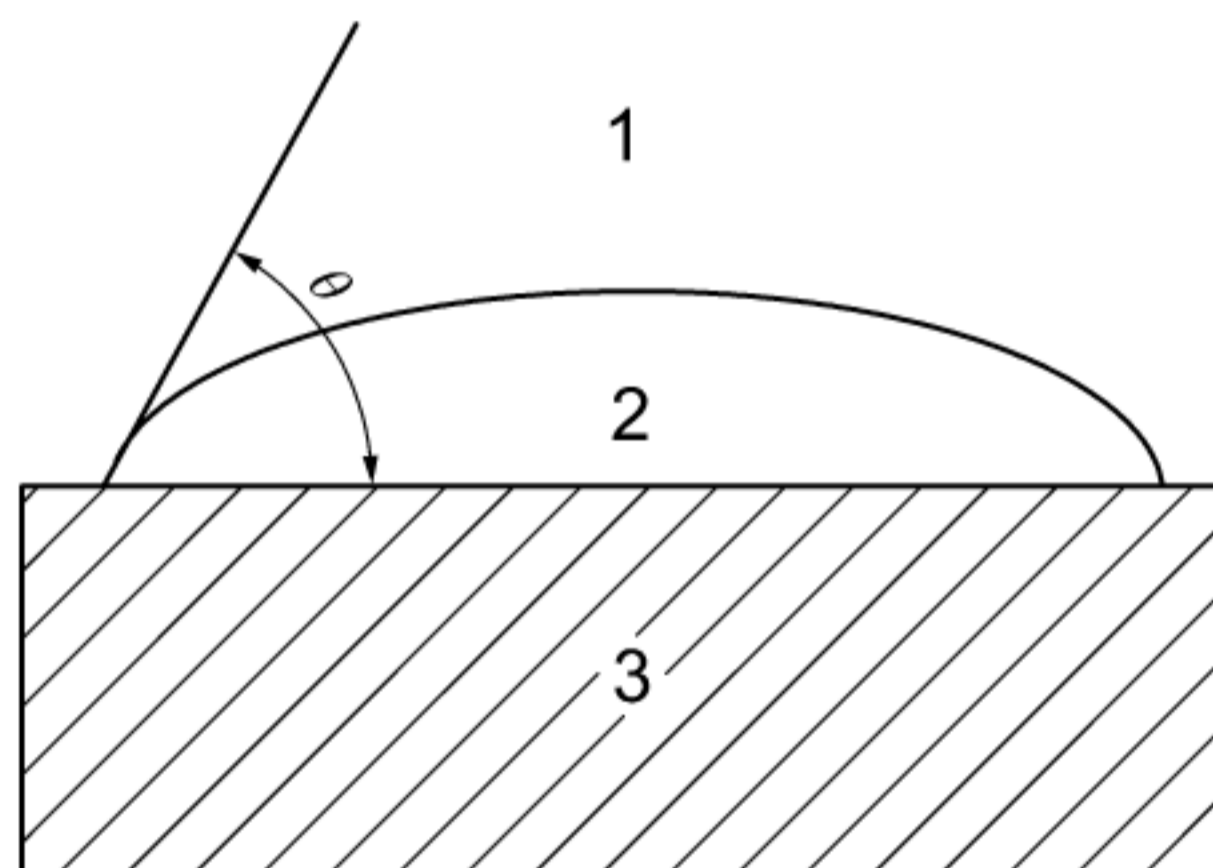

Key

- 1 gas
- 2 liquid
- 3 solid

Figure A.1 — Shape of a drop of liquid in contact with a solid surface when the contact angle is $\theta < 90^\circ$

Annex B (informative)

Descriptor for specific particle size ranges

B.1 Application

For particle sizes outside the range of the classification system, a differential descriptor can be used. This descriptor can also be used for specific particle size ranges that are of special interest. In these cases, the descriptor can be used in addition to the SCP classification.

B.2 Surface descriptor for specific particle size ranges

The N_{ss} (particle number concentration of a specific particle size range) descriptor for specific particle size ranges may be specified independently or as a supplement to the SCP classes. The descriptor can be applied to any particle size range of special interest.

The surface particle concentration C_s within the particle size range D_L and D_U is a differential value.

The N_{ss} for a single particle size range is expressed in the format:

$$N_{ss}(C_s; D_L; D_U) \ a; \ b \tag{B.1}$$

where

C_s is the maximum permitted total surface concentration, in particles per square metre of surface, of the specified particle size range;

D_L is the lower limit of the specified particle size range, in micrometres;

D_U is the upper limit of the specified particle size range, in micrometres;

a is the measurement method used to determine particle size in the specified range;

b is the considered surface.

EXAMPLE 1 For the particle concentration on a metallic surface in the particle size range between 1 μm and 5 μm , the required value is 10 000 particles/ m^2 (1,0 particles/ cm^2). The particle concentration is measured by an optical microscope. The designation would be:

$$N_{ss}(10\ 000; 1; 5) \text{ optical microscope; metallic surface}$$

If two or more size ranges are used, apply Formula (B.2). N_{ss} is then expressed in the format:

$$N_{ss} \begin{pmatrix} C_{s1}; & D_{L1}; & D_{U1} \\ C_{s2}; & D_{L2}; & D_{U2} \\ \dots & & \\ C_{si}; & D_{Li}; & D_{Ui} \\ \dots & & \end{pmatrix} \begin{pmatrix} a_1; & b \\ a_2; & b \\ \dots & \\ a_i; & b \\ \dots & \end{pmatrix} \quad (\text{B.2})$$

where

C_{si} is the maximum permitted total surface concentration, in particles per square metre of surface, of the i -th particle size range;

D_{Li} is the lower limit of the i -th particle size range, in micrometres;

D_{Ui} is the upper limit of the i -th particle size range, in micrometres;

a_i is the measurement method used to determine particle size in the i -th range;

b is the considered surface.

EXAMPLE 2 For the particle concentration on a glass plate, based on the simultaneous use of a scattered-light scanner in the particle size range between 0,1 μm and 0,5 μm , and an optical microscope in the particle size range between 5 μm and 20 μm , the measured values are 9 000 particles/ m^2 (0,9 particles/ cm^2) and 500 particles/ m^2 (0,05 particles/ cm^2), respectively. The values are within the maximum allowable limits of 10 000 particles/ m^2 and 500 particles/ m^2 , respectively. The designation would be:

$$N_{ss} \begin{pmatrix} 10\,000; & 0,1; & 0,5 \\ 500; & 5; & 20 \end{pmatrix} \begin{matrix} \text{scattered light scanner; glass plate} \\ \text{optical microscope; glass plate} \end{matrix}$$

When measurement methods and/or specific surfaces are not predefined or are not essential, designations a and b might be omitted. In this case, the descriptor is expressed as follows:

$$N_{ss} (C_s; D_L; D_U) \quad (\text{B.3})$$

where

C_s is the maximum permitted total surface concentration, in particles per square metre of surface, of the specified particle size range;

D_L is the lower limit of the specified particle size range, in micrometres;

D_U is the upper limit of the specified particle size range, in micrometres.

Where only one particle size is of interest, the lower and upper limit in Formula (B.3) might be used to frame the particle size of interest through an agreement between the customer and supplier.

EXAMPLE 3 For the particle size 5 μm , the required value is 200 particles/ m^2 (0,02 particles/ cm^2). D_L could be set to 4,5 μm and D_U could be set to 5,5 μm . The designation would be:

$$N_{ss} (200; 4,5; 5,5)$$

When measurement methods and/or specific surfaces are not predefined or are not essential, designations *a* and *b* might be omitted. The descriptor for two or more particle size ranges is expressed as follows:

$$N_{ss} \begin{pmatrix} C_{s1}; & D_{L1}; & D_{U1} \\ C_{s2}; & D_{L2}; & D_{U2} \\ \dots \\ C_{si}; & D_{Li}; & D_{Ui} \\ \dots \end{pmatrix} \quad (\text{B.4})$$

EXAMPLE 4 For the particle concentration in the particle size ranges between 0,1 µm and 0,5 µm and between 5 µm and 20 µm, the measured values are 9 000 particles/m² (0,9 particles/cm²) and 500 particles/m² (0,05 particles/cm²), respectively. They are within the maximum allowable limits of 10 000 particles/m² and 500 particles/m², respectively. The designation would be:

$$N_{ss} \begin{pmatrix} 10\ 000; & 0,1; & 0,5 \\ 500; & 5; & 20 \end{pmatrix} \quad (\text{B.5})$$

Annex C (informative)

Parameters influencing the SCP classification

C.1 Background

Parameters that may influence the testing and measuring of surfaces are presented in C.2. The information is not exhaustive and there is no ranking. More detailed information on measurement methods and surface characteristics is given in Annex D.

C.2 Parameters

C.2.1 Physical/chemical properties

- **Surface energy states.** The attraction and removal of particles might be influenced, for example, by cohesive/adhesive characteristics and/or hydrophilic/hydrophobic properties of the surface.
- **Porosity of the surface.** In most cases, the higher the degree of porosity, the more complex the distinction between surface imperfection and particle detection.
- **Cleanability of the surface.** When surfaces are difficult to clean, the discrimination between surface imperfection and particle detection is complex.
- **Optical characteristics of the surface.** When direct test methods are applied, different optical characteristics of the surface to be tested will lead to different measurement results. This difference is not noted for indirect methods.
- **Electrostatic properties of the surface.** The electrostatic properties of the surface will influence the attraction and removal of ESD-charged contamination.
- **Magnetic characteristics of the surface.** The magnetic characteristics of the surface will influence the attraction and removal of materials with magnetic properties.

C.2.2 Shape of the surface and particles

- **Morphology of the particle** (round, flat, oval, peaked, etc.) and topography of the surface can influence the measurement result.
- **Surface condition** (being cleaned, extruded, polished, etc.). The particle attachment force varies depending on the surface condition. This variation also affects the removal efficiency of particles and the ability to distinguish between particles, roughness and porosity.
- **Roughness/porosity/waviness of the surface.** The roughness, porosity or waviness will have an effect on the efficiency of removing particles for indirect methods.
- **Shape/geometry of particle.** The shape of particles can also influence the measurement results. For example, long particles and perfectly round particles can lead to the same optical particle counter values after detaching the particles from the surface, but to completely different gravimetric values. In general, fibres are considered as particles having an aspect (length-to-width) ratio of 10 or more.

C.2.3 Ability to measure/analyse and appropriate statistics for particle analysis

The number of measurements should lead to statistically significant results. Therefore, an appropriate statistical method with regard to the frequency distribution of individual measurements should be used to estimate the confidence limit.

- **Ability to measure/analyse.** Feasibility to perform the measurements, depending on the accessibility of a measurement device to the specimen.

EXAMPLE Performing measurements within holes or microtubes.

- **Ability to detect particles** (direct or indirect methods). The ability to distinguish between surface sedimented particles and surface imperfections (direct method) or the detachability of surface sedimented particles (indirect method) will influence the SCP classification.
- **Geometric size/surface area to be measured.** Depending on the geometric size of the surface area to be measured, different methods should be selected. In the majority of cases, the statistics for the number of samples to be taken and how to analyse the measurement values should be developed individually.
- **Inline capability.** Several measurements should be taken for statistical significance. The influence of measurement repeatability is diminished with inline options.
- **Frequency distribution of individual measurements.**
- **Particle size(s) to be measured.**
- **Distribution of particles on surface area.**

C.2.4 Particle origin

Particles on the surface can originate, for example, from material friction, deterioration, deposition of airborne particles or chemical reaction of gaseous matters with the surface, forming solid or liquid products.

EXAMPLE $2\text{NH}_3 + \text{H}_2\text{O} + \text{SO}_3 \rightarrow (\text{NH}_4)_2\text{SO}_4$.

Annex D (informative)

Measurement methods for determining surface cleanliness by particle concentration

D.1 Surface cleanliness by particle concentration

In order to obtain quantitative information on surface cleanliness, appropriate measurement methods should be selected. In some cases where quantitative information cannot be ascertained on a surface, it is possible at least to obtain a qualitative result. Qualitative results cannot be used for the surface cleanliness by particle concentration classification defined in Clause 5.

D.2 Criteria for the measurement of surface cleanliness by particle concentration

D.2.1 General

The cleanliness of surfaces can be classified as soon as the particle contamination is detectable.

As a quantitative criterion for the evaluation and classification of the surface cleanliness, the number of all adherent particles of undesired material should be determined. It should be possible to determine the dimension and number in relation to the contaminated surface area (surface particle contamination).

NOTE The cleanliness classification of textiles and/or porous surfaces also takes into account particles which might emanate from the specimen.

D.2.2 Requirements of the measurement method

The measurement method is essentially selected according to criteria determined by the surface being tested and its characteristics. Some of the most important requirements are summarized below:

- information regarding particle characteristics (e.g. particle size, concentration, size distribution, material, shape, position);
- feasible measuring positions (transportable measuring device, i.e. applicable even to large immovable surfaces);
- measurements independent of surface characteristics (e.g. roughness, waviness, component shape);
- testing speed and effort involved (i.e. use of random sampling or series testing);
- flexibility (i.e. whether the method can be rapidly implemented on various surfaces of different components);
- little or no surface alteration caused by the measurement procedure (i.e. measurement surfaces are not altered as a result of being wetted with flushing fluids).

Due to the requirements mentioned, the measurement methods described in D.2.3 could be classified and be limited for each of the applications.

D.2.3 Measurement methods

D.2.3.1 General

Ideally, surface cleanliness is assessed when test surfaces are of a low roughness and can be accessed by the chosen measurement device. In principle, the following methods can be utilized to measure the particle cleanliness of surfaces:

- direct methods;
- indirect methods.

In most cases, direct methods that do not require sample taking should be given priority. Generally, these methods involve less measurement activity and are associated with fewer errors, thus giving more reproducible results than indirect methods. However, depending on component and manufacturing requirements (complex component shape, rough surface), indirect methods are often the only possible alternative in order to determine the particle cleanliness of a surface.

D.2.3.2 Direct methods

Particles are recorded and measured directly on the test surface. Neither the component surface nor the particles present on it should be altered or affected by the measurement. If a testing surface requires transport to a measuring device, the transportation (handling, packaging) should be carried out so as to avoid any further contamination from reaching the surface.

The methods are given in Table D.1 and have been characterized here according to the requirements to be fulfilled and the limitations of the methods.

Table D.1 — Comparison of measurement methods for the direct detection of particles on surfaces

Method	Detection limits	Determination of concentration	Size distribution	Material analysis	Shape analysis	Determination of position	Transportability	Independent of surface	Accessibility	Testing speed	Flexibility	Influence on surface
Visual inspection	> 25 µm	+	+	+	+	+	++	+	+	++	++	++
Light microscope (with image-processing)	> 1,0 µm	++	++	+	++	++	+	+	+	++	++	++
Oblique-, glancing-, side-light systems (with image-processing)	> 0,5 µm	++	++	+	+	++	++	+	+	++	++	++
Scattered-light scanner	> 0,07 µm	++	++	—	++	++	—	—	—	++	—	++
SEM	> 0,01 µm	+	+	++	++	++	—	—	—	—	+	+
AFM	> 0,01 µm	+	+	++	+	++	+	+	+	—	+	+

Key: ++ highly suitable, + partially suitable, — unsuitable/not useful.
 Particles that are not perfectly round should be measured on their largest axis.

The efficiency of optical methods to detect particles on surfaces can be enhanced by the additional use of suitable light sources that are based on specific material effects (e.g. UV-, IR-activity). If, for instance, a UV-lamp is used, particles that are physically UV-active will be detected with a much better contrast.

Within the visible light spectrum, the colour/reflection grade of particles can be used for further discrimination of particle contamination.

D.2.3.3 Indirect methods

D.2.3.3.1 General

Since direct counting is often not possible on the surface of interest due to either object-related or measurement-related reasons, samples should be prepared before inspection. The particles to be recorded are detached from the testing surface (sampling) and are placed on/in a replacement substrate/medium. The particles are then measured using a technique adapted to the replacement substrate/medium concerned (see IEST-STD-CC1246D).

The measuring efficiency is reduced if not all particles that settled on surfaces can be detached from the testing surface by indirect methods.

Due to physical/chemical effects, such as adhesion/cohesion, electrostatic forces, etc., the detachment force may be insufficient, resulting in diminished measuring efficiency of surface particle contamination. Therefore, direct measurement is preferred.

However, care should be taken if more aggressive methods are used to remove particles from a surface, as such methods may erode a surface and form additional particles. The test method should be evaluated for this potential effect.

When using indirect methods, the background particle contamination of the intermediate media (e.g. flushing medium) should be known.

D.2.3.3.2 Detachment techniques

In the case of surfaces that are difficult to access due to the complex shape of a component, drawing samples with detached particles is often the only way of assessing surface cleanliness by particle concentration. The smaller the particles become, the more difficult it will be to detach them from surfaces, as several surface forces (e.g. electrostatic, cohesion, adhesion, capillary) increase. For the detachment of particles from tested surfaces, techniques such as the following can be used.

- **Tape-lifting.** The particles to be recorded are detached using a clean adhesive replacement substrate (adhesive tape or stamp) (see ASTM E1216-06) and guided directly to a measurement process (see ASTM F312-08).
- **Flushing.** The particles to be recorded are rinsed off using a clean flushing medium, e.g. gas or liquid (see ASTM F24-09). The particles contained in the measurement media are then examined using appropriate measuring devices (e.g. optical particle counters for gases) or the particles held in the medium are deposited on a replacement substrate (filtration, impaction) and then measured.

In all sampling cases, care should be taken to ensure that samples are not further contaminated by the devices or media used or by personnel, as this contamination would affect the measurement result. The contamination brought in from the environment, processes and materials used for the inspection procedure should be less than 10 % of the presumed or specified particle numbers, at the relevant sizes, with each number calculated being rounded down (see ISO 16232-2, ISO 16232-3, ISO 16232-4, ISO 16232-5). Furthermore, the sampling method chosen should be capable of detaching the required particles reliably and completely from the testing surface. Flushing the sampling equipment should be capable of ensuring the complete transfer of the particles present to the measurement medium or replacement surface. To optimize the sampling method, blank samples (i.e. sampling on a clean surface) or samples from surfaces contaminated in a defined way can be used.

D.2.3.3.3 Measurement of the medium being used for detaching surface sedimented particles

The particles present in the gaseous or liquid flushing medium that was used for detaching surface sedimented particles can be measured directly using appropriate optical particle counters (see D.2.7.4). The low test-flow rate of optical particle counters does not permit large volumes of flushing media to be measured completely. Therefore, a representative sample should be taken from the flushing volume. Especially in the case of large particles ($> 3 \mu\text{m}$), care should be taken to avoid any separating out or sedimentation of the particles as this would create an inaccurate measurement result. As with sampling techniques, sampling equipment and associated tubing should be kept clean when measuring flushing media.

D.2.3.3.4 Collection method

The particles detached from the testing surface are present in either a gaseous or a liquid flushing medium. In order to measure the number of the particles, they are first deposited on a surface. The substitute surface is then passed to the corresponding measurement systems for examination. For particle collection, methods and devices such as the following can be used.

- **Filtration systems** (liquid drawn through a filter membrane via a sucking strainer or liquid poured onto a filter medium). The flushing medium is guided through filter membranes possessing an appropriate pore size for the particle size to be determined. The filters containing the particles are then dried and analysed either gravimetrically (see D.2.7.7) or microscopically (see D.2.6.2 and D.2.7.2).
- **Impactors**. Particles are deposited from gaseous flushing media onto an impaction plate. The impaction plates are then analysed microscopically.

All devices and handling steps associated with the collection process are subject to correspondingly high cleanliness requirements. Their level of cleanliness should be stated using blank samples.

D.2.3.3.5 Most frequently used indirect methods (see Table D.2)

For detachable particle size/efficiency of indirect measurement methods, smaller particles (smaller than approximately $1 \mu\text{m}$) require a greater effort for removal from the surface for indirect measurement. The efficiency of a given method in detaching particles from surfaces is not only dependent on the particle size, but is also related to the following parameters:

- shape and material of particles;
- existence of surface forces (e.g. electrostatic, cohesion, adhesion, capillary);
- detaching method (e.g. ultrasonic, megasonic, flushing, purging, blowing, drawing).

Due to the different methods used to overcome forces between particles and surfaces, and the interaction between these factors, the efficiency to detach particles varies significantly. Therefore, discrete values for the efficiency of indirect methods cannot be given.

To obtain additional information from indirect methods, analytical methods such as ESCA, EDX, Raman, UV or IR spectroscopy can be used for the characterization of particles.

Table D.2 — Comparison of measurement methods for the indirect detection of particles on surfaces

Method ^a	Limit of the detachment procedure	Estimation on limits of the measurement method	Determination of concentration	Size distribution	Material analysis	Shape analysis	Determination of position	Transportability	Independent of surface	Accessibility	Testing speed	Flexibility	Influence on surface
Examination of flushing medium (liquid/gaseous) using <u>extinction particle counters</u> (> 1 µm)	0,2 µm	> 1 µm	++	++	—	—	—	++	++	++	+	++	—
Filtration or impaction of flushing medium and <u>microscopic analysis</u> (> 0,5 µm)	0,2 µm	> 1 µm	++	++	+	++	—	+	++	++	—	++	—
Examination of flushing liquid using an <u>OPC</u> (start with flushing particles off the surface then draw them through an OPC) (> 0,05 µm)	0,2 µm	> 0,2 µm	++	++	—	—	—	++	++	++	+	++	—
Examination of gaseous medium using an <u>OPC</u> (start blowing particles off the surface then draw them through an OPC) (> 0,05 µm)	0,3 µm	> 0,3 µm	++	++	—	—	—	++	++	++	+	++	—
Filtration of flushing medium and <u>gravimetric analysis</u> (> 0,1 mg)			++	—	—	—	—	++	++	++	—	++	—

Key: ++ highly suitable, + partially suitable, — unsuitable/not useful.

NOTE Use of microscopic or gravimetric analysis: whether filters can be examined with microscopic or gravimetric analysis depends on the total number of particles found on the filters. The size of the particles is not a decisive factor. Empirically determined reference value: microscopic analysis is not possible for contamination greater than 3 mg on the surface of a filter (standard filter size of 47 mm) (see ISO 16232-2, ISO 16232-3, ISO 16232-4, ISO 16232-5). Gravimetric analysis is not suitable for classification of SCP classes, as no discrete single particles will be measured. Gravimetric analysis is used to determine the total mass of all contamination detached from the test surfaces.

^a Figures in parentheses are detection limits of the measurement devices.

D.2.4 Determination of number of samples

The number of measurement points used and the overall surface under investigation determine the statistical certainty of the measurement results. As the measurement results in general are dependent on different influencing parameters (e.g. specific surface characteristics, selected measurement method, cleanliness of the environment), the number of measuring points and measurement repeats should be agreed between the customer and the supplier performing the measurements.

For the determination of the number of samples to be taken with the goal of achieving statistically verified measurement results, pertinent standards or guidelines might be helpful (e.g. ISO 5725-2; ISO/TS 21748; ISO 10576-1).

D.2.5 Packaging of test samples

D.2.5.1 Packaging of samples for particle examination

Samples that are to be assessed for particles outside the area of origin should be packaged as follows.

- a) Preparation should take place inside the area of origin by personnel wearing the correct cleanroom clothing.
- b) Samples should be handled by personnel wearing a new pair of washed nitrile or latex cleanroom gloves.
- c) When a cleaning process has been used, it is essential that the samples are allowed to cool and dry before placement in the package or bag.
- d) Cleanroom-produced metallized polymer bags that are used should be at least one cleanliness level better than the anticipated sample requirement. The minimum thickness should be 80 µm to avoid tearing.
- e) Each sample should be bagged separately using both an internal and an external bag of the type described in item d).
- f) Bespoke sealed boxes such as wafer carriers or PET vacuum-formed containers may also be used, providing they are also one level cleaner than the subject sample.
- g) Each sample should be individually bagged inside the bespoke pack using the type of bag identified in item d) to avoid particle release by abrasion or contact.
- h) The internal bag should be folded and sealed with adhesive tape to avoid particle release during subsequent cutting and an identity label should be fixed to the outside.
- i) The external bag should be sealed and welded to avoid tampering and a suitable label should be applied to prevent opening outside a controlled environment.
- j) Where bespoke pack boxes such as those described in item f) are used, two outer polyethylene film bags of the cleanliness level in item d) will also be required. The inner film bag may be taped or welded, while the outer film bag should be welded.

D.2.5.2 Removal from packaging

The exterior bag should be removed immediately before entering the controlled test environment.

The interior bag should not be removed before arrival in the controlled test environment.

Full cleanroom garments, including a hood and face mask, should be worn when handling the interior pack.

A new pair of washed nitrile or latex cleanroom gloves should be used when examining the samples.

D.2.6 Measurement techniques

D.2.6.1 Visual inspection

In some applications, especially where surface cleanliness is low, a visual inspection of the cleanliness level of a surface may be sufficient. By supporting the human eye using simple aids, such as a magnifying lens with graticule or contrast-rich illumination, particles > 25 µm can be recorded. Complex components can be rapidly and qualitatively examined. Quantitative information with regard to particle size and distribution cannot be obtained in this way.

D.2.6.2 Light microscopy

Light microscopes are economical and have a wide range of applications. Contamination is characterized according to their morphology; optical characteristics, such as absorption, light refraction, or double refraction; or by determining thermal ratings (e.g. softening or melting behaviour) using a heating-stage microscope. Particles with sizes of 1,0 μm and larger can be detected on solid and in liquid samples (e.g. collect sample using ASTM F303-08 and analyse per ASTM F312-08 methods). Where particles do not contrast sufficiently against the surface, viewing can be improved using dark-field illumination. This method gives qualitative results. By using automatic sampling stages and automated image analysis, areas of samples or component surfaces can be examined.

D.2.7 Further measurement systems

D.2.7.1 Oblique-, glancing- and side-light measurement systems

As with light microscopy, the image of a surface is depicted on a digital camera using the required magnification. By using oblique illumination with parallel light on the surface, existing surface structures are only minimally illuminated. In this way, only a small amount of light is scattered by the surface and enters the camera. The clean surface appears dark. However, if particles are present on the surface, they are completely illuminated by the oblique light and the corresponding amount of scattered light is generated by the particles. In the camera image, bright dots are seen on a dark background and the morphology of the dots can be analysed using simple image-analysis algorithms.

D.2.7.2 Scanning electron microscopy (SEM)

Where the resolving capacity of light microscopic systems is exhausted and where surfaces are especially rough, SEMs can be used. Due to their small depth of field at high degrees of magnification, investigation of rough surfaces exceeds the limits of light microscopic systems. However, it is difficult to examine non-conducting surfaces using SEMs because the surface becomes charged on being bombarded by the electron beam, with the result that imaging is distorted. To avoid this, non-conducting surfaces should first be sputtered with a thin (mostly metallic) layer in order to be made conductive. Here, there is a risk that surface conditions will be altered. Additionally, particles may become charged by the electron beam and be blasted off the surface. As the testing surface or component needs to be placed in a high vacuum for an SEM test, care should be taken to ensure that the component is not damaged or altered in the vacuum. When SEM is combined with image analysis devices, surfaces can be examined automatically.

D.2.7.3 Energy-dispersive (EDX) measurement methods

The elemental composition of particle material can be determined using wavelength-dispersive (WDX) or EDX measurement methods. When EDX is used in conjunction with calibrating compounds, not only quantitative but also qualitative information can be obtained.

D.2.7.4 Optical particle counting

Media (air, gases and liquids) are guided through a laser beam. If particles are present in the medium, on passing through the laser they generate scattered light that is registered by photo-detectors and analysed. The intensity of the scattered light enables conclusions to be drawn regarding the size of the particle that triggered the light impulse. These conclusions of size can be made based on a calibration curve obtained using round latex particles. However, the diameter obtained is equal to the scattered-light impulse and not the actual particle diameter. The measurement result gives a particle size distribution within a defined measurement volume. For measurements performed in air and gases, different sensors are available that can measure particles as small as 0,05 μm and as large as 2 500 μm (2,5 mm). The measurement range of a sensor depends on its optical design. Smaller particles can be recorded using condensation nucleus counters (CNCs). By condensing a liquid, particles are magnified before measurement. Particles as small as 0,005 μm can be recorded using CNCs. However, because the liquid has been condensed, particle distribution cannot be determined. When CNCs are used to measure particles in liquids, a detection limit of > 0,05 μm applies. In general, with an OPC, discrete particle measurements are performed.

D.2.7.5 Light-extinction particle counting

In both methods of detecting particles (extinction and scattering of light) a change in light intensity measured by the detector is converted to an electrical signal. Light extinction is useful for particles 1 µm and greater in size. In this method, the detector looks directly into the light source and measures the size of the “shadow” of the particle as it passes through the beam.

D.2.7.6 Scattered-light surface scanning device

Scattered-light scanners are implemented especially to examine surfaces with a very low roughness (e.g. silicon wafers, glass). A focused laser scans the component surface using a defined beam angle. The light reflected directly from the surface is guided into a light trap and thus eliminated. Particles present on the surface cause the laser light to be diffusely scattered. The scattered light is registered by a photomultiplier and amplified. Using subsequent analysis electronics, conclusions can be drawn about the size and shape of the particles based on the intensity of scattered light detected and the size of the scattered-light event. By synchronizing the actual position of the laser with the occurrence of scattered-light events, surface particle distribution can be determined. The detection limit of scattered-light scanners lies at a particle size of > 0,05 µm.

D.2.7.7 Gravimetry

The particle load on a surface or test object is determined by the increase in mass of an analysis filter (differential weight). To do this, the analysis filter is weighed before and after filtration of the flushing liquid using precision scales. Gravimetry provides the total mass of the particle load but does not indicate the size distribution of the particles on the analysis filter. In order to carry out such precise weighing procedures, the analysis filters should be prepared and dried very carefully. To prevent results from being altered by environmental influences; ambient temperature, humidity, air cleanliness and handling steps should all remain constant and the handling steps should be carried out in a defined way. As single particles cannot be recorded using gravimetry, this method is utilized mainly to determine the particle load on large-sized or complexly shaped components. The measurement limit lies at approximately 0,1 mg per analysis filter.

D.2.7.8 Analysis by atomic force microscopy (AFM)

The atomic force microscope is a very-high-resolution type of scanning probe microscope, with demonstrated resolution of fractions of a nanometre, more than 1 000 times better than the optical diffraction limit. The AFM consists of a microscale cantilever with a sharp tip (probe) at its end that is used to scan the specimen surface. When the tip is brought into proximity of a sample surface, forces between the tip and the sample lead to a deflection of the cantilever. Typically, the deflection is measured using a laser spot reflected from the top of the cantilever into an array of photodiodes. The resulting map of the area represents the topography of the sample.

D.2.7.9 Analysis of the measurement results

When tasks (scope of measurement) or results have been mutually agreed upon, the sampling and measurement methods to be implemented should be planned, accepted, analysed and documented by the customer and supplier. Surface cleanliness by particle concentration classes should be used for classification purposes, especially if additional aspects are to be covered when comparing separate locations and systems or when comparing measurement results with similar measurement methods (aerosols, hydrosols).

D.3 Documentation of surface cleanliness by particle concentration

Documentation should include all necessary information as stated in 6.3, such as cleanliness conditions and cleanroom compatibility, to enable reproducibility of particle measurement.

Bibliography

- [1] ISO 4287:1997, *Geometrical Product Specifications (GPS) — Surface texture: Profile method — Terms, definitions and surface texture parameters*
- [2] ISO 4288:1996, *Geometrical Product Specifications (GPS) — Surface texture: Profile method — Rules and procedures for the assessment of surface texture*
- [3] ISO 5725-2:1994, *Accuracy (trueness and precision) of measurement methods and results — Part 2: Basic method for the determination of repeatability and reproducibility of a standard measurement method*
- [4] ISO 10015:1999, *Quality management — Guidelines for training*
- [5] ISO 10576-1:2003, *Statistical methods — Guidelines for the evaluation of conformity with specified requirements — Part 1: General principles*
- [6] ISO 16232-2:2007, *Road vehicles — Cleanliness of components of fluid circuits — Part 2: Method of extraction of contaminants by agitation*
- [7] ISO 16232-3:2007, *Road vehicles — Cleanliness of components of fluid circuits — Part 3: Method of extraction of contaminants by pressure rinsing*
- [8] ISO 16232-4:2007, *Road vehicles — Cleanliness of components of fluid circuits — Part 4: Method of extraction of contaminants by ultrasonic techniques*
- [9] ISO 16232-5:2007, *Road vehicles — Cleanliness of components of fluid circuits — Part 5: Method of extraction of contaminants on functional test bench*
- [10] ISO/TS 21748:2004, *Guidance for the use of repeatability, reproducibility and trueness estimates in measurement uncertainty estimation*
- [11] IEC 61340-5-1:2007, *Electrostatics — Part 5-1: Protection of electronic devices from electrostatic phenomena — General requirements*
- [12] ASTM E18-07, *Standard Test Methods for Rockwell Hardness of Metallic Materials*
- [13] ASTM E1216-06, *Standard Practice for Sampling for Particulate Contamination by Tape Lift*
- [14] ASTM F312-08, *Standard Test Methods for Microscopical Sizing and Counting Particles from Aerospace Fluids on Membrane Filters*
- [15] ASTM F24-09, *Standard Method for Measuring and Counting Particulate Contamination on Surfaces*
- [16] ASTM F303-08, *Standard Practice for Sampling for Particles in Aerospace Fluids and Components*
- [17] CLC/TR 61340-5-2:2008, *Electrostatics — Part 5-2: Protection of electronic devices from electrostatic phenomena; User guide*
- [18] IEST-RP-CC022.2-2004, *Electrostatic charge in cleanrooms and other controlled environments*
- [19] IEST-STD-CC1246D, *Product Cleanliness Levels and Contamination Control Program*
- [20] SEMI E43-0301, *Guide for Measuring Static Charge on Objects and Surfaces*

- [21] SEMI E78-0706, *Guide to Assess and Control Electrostatic Discharge (ESD) and Electrostatic Attraction (ESA) for Equipment*
- [22] Adamson, A.W. *Physical Chemistry of Surfaces*, John Wiley & Sons, New York, 1976

This page has been left intentionally blank.